

LIGHT

IP65-67 JUNCTION BOXES

Description: IP65-67 MOTOR-PROTECTION BOX 175x151x155 WITH KNOCK-OUT ENTRIES

Reference:
GSX171

Characteristics:

Product type:	Motor-protection boxes with opaque cover and knock-out entries
Exterior dimensions (Height x Width x Depth):	151x175x155 mm
Dimensions of the flush-fit gap (HxWxD):	-
Number of modules:	-
Installation:	Surface
Color:	Grey RAL 7035
Window:	Opaque cover
Weight (Kg):	0,43
Cable entry:	6xM25 - 4xM40
Components:	-
Materials:	Halogen-free plastic materials. Base and cover: Shock-proof PS

Technical data:

Degree of protection:	IP65-IP67
Resistance to impact:	IK07
Glow wire resistance:	650 °C
Ball pressure test:	70 °C
Ambient temperature range:	-25 °C / +40 °C
Maximum operating voltage:	1000 V AC / 1500 V DC
Double insulation:	Class II

Certificates and standards:

Directive:	2014/35/EU
Standards:	IEC 60998-2-5
Certificates:	



Codes:

EAN:	8431044198101
Customs tariff number:	85.38.10.00
ETIM 6.0:	EC000113

LIGHT

IP65-67 JUNCTION BOXES

Description: IP65-67 MOTOR-PROTECTION BOX 175x151x155 WITH KNOCK-OUT ENTRIES

Reference: GSX171

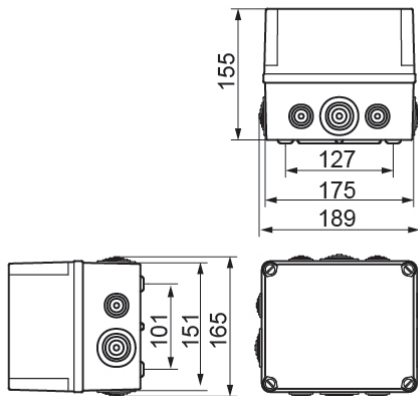

Detailed drawing:

 <http://www.ide.es/downloads/planos/pdf/GSX171.pdf>

 <http://www.ide.es/downloads/planos/dxf/GSX171.dxf>

 <http://www.ide.es/downloads/planos/stp/GSX171.stp>

Exterior dimensions (Height x Width x Depth):

151x175x155 mm

Dimensions of the flush-fit gap (Height x Width x Depth):

-

Sustainability:

RoHS - REACH

Supply:

The boxes are supplied individually, shrink-wrapped and in multiple cardboard packaging, according to minimum packaging units.

Packaging units: 12

Product end of life:

It does not require specific recycling operations.

Recommended applications:

Industrial and outdoor environments. Industrial sites, docks, swimming pools, garages, anywhere that requires a high degree of protection against dust, splashes and impacts.